



LL Series

Liquid Level Controllers



Operating Instruction Manual

Contents

1	General Information	3
2	Specifications	4
3	Setup	5
3.1	Location.....	5
3.2	Sensitivity (AM-LL7H only)	5
3.3	Time delay (AM-LL3 only)	5
4	Wiring.....	5
4.1	Single Level vs Differential Level.....	5
4.1.1	Single Level.....	6
4.1.2	Differential Level	6
4.2	AM-LL3 wiring	6
4.2.1	Differential Level Wiring	7
4.2.2	AM-LL3 Single Level Wiring.....	8
4.3	AM-LL7H Wiring.....	10
4.3.1	AM-LL7H Differential Level Wiring.....	10
4.3.2	AM-LL7H Single Level Wiring	11
5	Accessories.....	12
5.1	Suspended Electrodes (AM-ELE).....	12
5.2	Junction box.....	13
5.3	Spare parts:	13
6	Warranty	13
7	Troubleshooting.....	13
7.1	AM-LL7H:.....	13
7.2	AM-LL3:	13

1 General Information

The AquaMetrix LL Series Liquid Level Controllers operate on the principal of electrolytic conductivity. All aqueous solutions conduct electricity, the degree of conductivity is directly related to the amount of dissolved particles in the solution. The purer the water, the less conductive the solution will be. These controllers are suitable for use in solutions having a conductivity of 15 $\mu\text{S}/\text{cm}$ or greater.

By placing two electrodes into a solution and applying voltage across them, the controller can detect when the solution rises and makes contact with both electrodes, completing the circuit. The completed circuit sends enough current back to the controller to trigger the relay on or off, like a light switch. The relay in turn may be wired to auxiliary devices such as pumps, alarms, and actuators.

The AM-LL7H has a sensitivity adjustment, which allows to adjust to a solution of different conductivity. For example, since foam is less conductive than liquid, sensitivity could be adjusted to either ignore the foam level and respond only to the liquid, or to be triggered by the foam.

The AM-LL3 has a delay timer. User can adjust delay before the actuating the relay versus delay to disengage.

2 Specifications

Parameters	AM-LL3	AM-LL7H
Input Voltage	120VAC or 240VAC (Field configurable)	120VAC or 240VAC (Field configurable)
Power Consumption	<50 mA at 120 VAC	<25 mA at 120 VAC
Enclosure Materials	Clear molded plastic UL 94 V-0	Black ABS NEMA 1 Enclosure
Base Material	Break resistant thermoplastic	Break resistant thermoplastic
Max Distance to Electrodes	2,000 ft (600 m)	2,000 ft (600 m)
Ratings		
Number of Relays	2 SPDT	1 SPDT and 1 AUX NO
Relay Ratings (resistive load)	Dry contact 10A @ 250VAC	Dry contact 10A @ 240VAC
Max Sensitivity	10k Ω (not adjustable)	10K to 1M Ω (Field Adjustable)
Temperature	-40 to 80°C (-104 to 176°F)	-17.8 to 55°C (0 to 131°F)
Physical		
Mounting Options	Wall Mounted Base	Wall Mounted Base
Dimensions	Case: 3.41" x 2.63" x 1.5" Base: 2.66" x 2.20" x 0.90"	Case: 4.61" x 3.10" x 1.77" Base: 2.66" x 2.20" x 0.90"
Weight	Less than 1 lb.	Less than 1 lb.

3 Setup

3.1 Location

Choose an installation site that is free of mechanical vibrations, reasonably clean and dry, protected from falling corrosive fluids, and away from high voltage relay and power switches. Installation site should prevent the exposure of contacts to water. The base for controller is wall mountable. The electrodes should be within 2,000 feet of the controller. The electrodes come with a 15ft cable, if that cable length is not sufficient, a junction box (AM-JB2) and extension cable (AM-CBL) can be used.

3.2 Sensitivity (AM-LL7H only)

The controller includes a sensitivity adjustment that is accessible through a side hole on the enclosure. The hole is plugged for ingress protection.

The default configuration is set to operate in the full conductivity spectrum: up to 1 M Ω between electrodes. The user can turn the trim pot CCW to make the controller less sensitive which enables it to ignore a solution with a smaller conductivity such as foam or less conductive layer. This should be adjusted according to the user's application.

3.3 Time delay (AM-LL3 only)

The AM-LL3 features a time delay which can be used to prevent the pump from burning out due to frequent power cycling. This feature prevents the controller from engaging until there is a consistent contact with the electrodes. If the controller is being used at a site where there are waves or splashing, the time delay will cause the controller to only engage when the liquid touches the electrode for a few consecutive seconds.

The time delay is adjustable by turning the trim pot via a hole located at the top of the controller. If the trim pot is turned fully CW, the relay will engage immediately after there was a contact between two electrodes and disengage after about 5 seconds. If the trim pot is turned fully CCW, there is a 2 second delay to both engage and disengage the relay.

4 Wiring

CAUTION: The instrument operates from a live AC voltage. This constitutes a possible shock hazard. Ensure that power is removed before attempting connections.

The LL Series Controllers include the removeable base. The 12-pin base is designed to be wall mounted and pre-wired to establish all electrical connections. The relay in the controller is dry contact, i.e. there is no voltage on relay contact.

4.1 Single Level vs Differential Level

The Liquid Level controller can be wired as both single or differential level.

4.1.1 Single Level

Single level service uses two electrodes: one level electrode and one ground electrode (or metallic tank). Depending on the application, the pump, valve, or an alarm can be connected to either NO or NC relay contacts. As soon as the liquid reaches the level electrode, the relay would engage. The best use for a single level service is low/high alarm, however, this configuration may also be used to control a slowly changing liquid level. Please note that if this is used with a liquid whose level changes quickly, the frequent relay activation will affect the longevity of the pump's life.

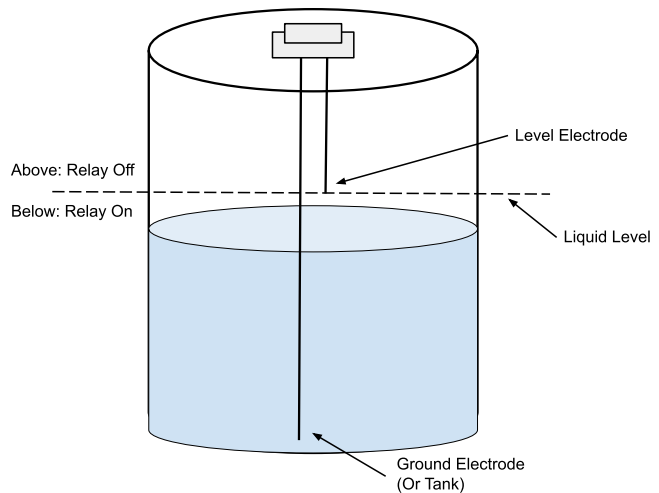

4.1.2 Differential Level

Differential level service adds a hysteresis (or dead band) to a relay operation which prevents the system bounce quickly between On and Off operations. Differential level requires three electrodes: tank, long, and short. Long and short electrodes can be configured as pump on or pump off depending on the application needs. Differential service is used primarily to maintain accurate level in a tank.

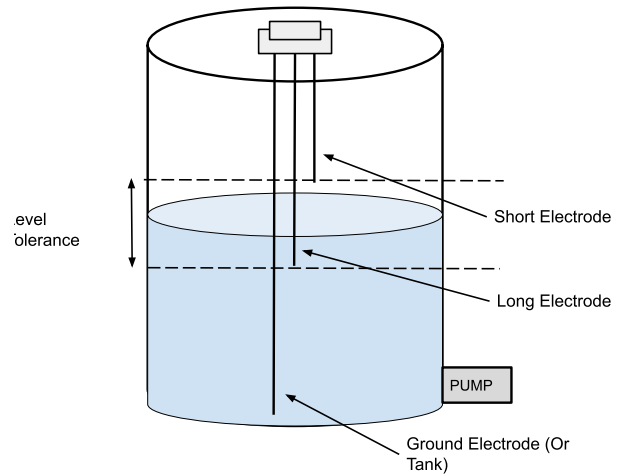

4.2 AM-LL3 wiring

Once the appropriate application is determined, start by wiring the electrodes to the base according to 4.2.1 (Differential level) or 4.2.2 (Single level). If the electrodes are wired for differential service, only one relay is available for use. For single level service, both relays are available.

4.2.1 Differential Level Wiring

Differential Level Service uses two or three level electrodes: one short, one long, and one ground electrode that is always in contact with the liquid (or conductive tank). As the liquid reaches the short electrode, the relay is activated, and it only deactivates when the liquid no longer touches both the long and short electrodes. This results in a level tolerance in between the long and short electrodes, which can be adjusted by changing the distance between the two electrodes.

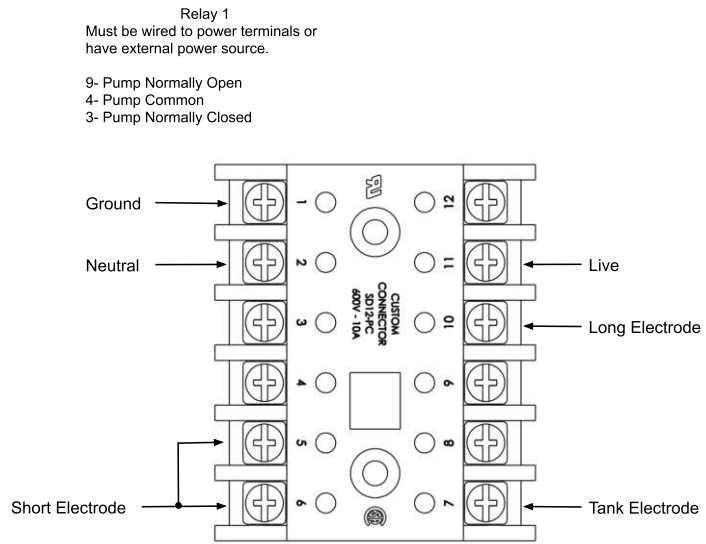

NOTE: If the tank is metallic (i.e. conductive on the inside), connect the tank to the “tank electrode” receptacle on a base. For nonconductive tanks, use an electrode that is constantly submerged.

4.2.1.1 Pump Up Application

When the liquid falls below the long electrode, the relay will engage, and the pump will turn on. When the liquid reaches the short electrode, the relay will disengage, and the pump will turn off.

For this configuration, connect the pump through the normally closed relay on the base (terminals 3 and 4).

NOTE: Pump must be externally powered.

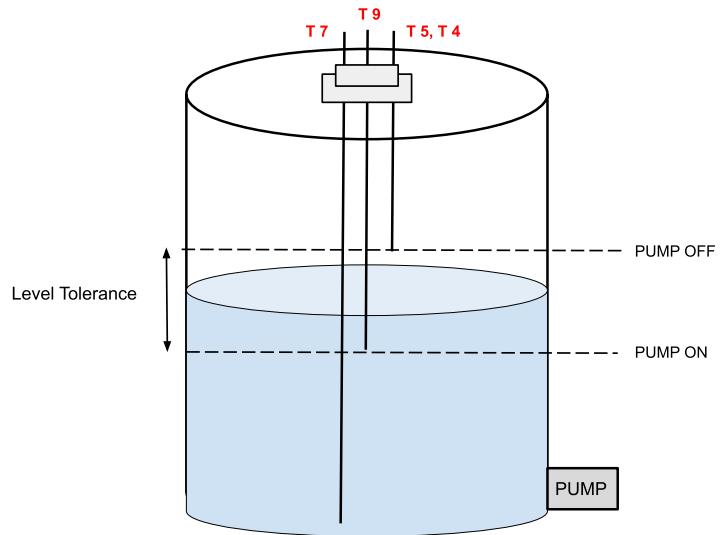

4.2.1.2 Pump Down Application

When the liquid level reaches the short electrode, the relay will engage, and the pump will turn on. When the liquid level falls below the long electrode, the relay will disengage, and the pump will turn off.

For this configuration connect the pump through the normally open relay on the base (terminals 4 and 9).

NOTE: Pump must be externally powered.

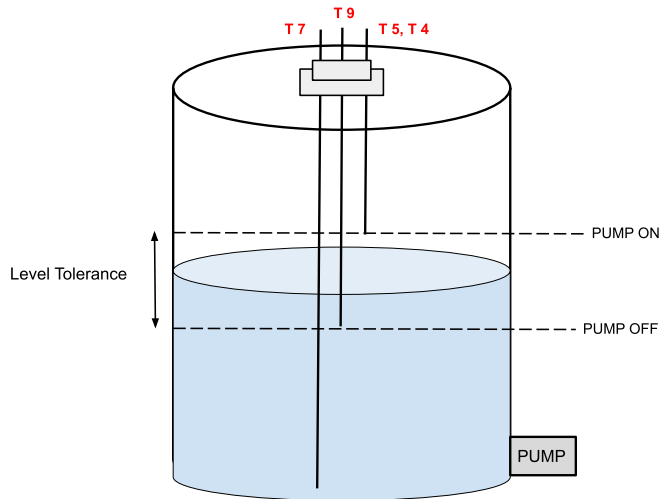

4.2.2 AM-LL3 Single Level Wiring

Single Level Service uses two electrodes: one level electrode and one ground electrode (or metallic tank). As soon as the liquid reaches the level electrode, this will create a circuit with the ground electrode (or the tank) and activate the relay.

Please note that since single level wiring results in frequent power cycling of the pump, it is recommended that this setup only be used in an alarm application.

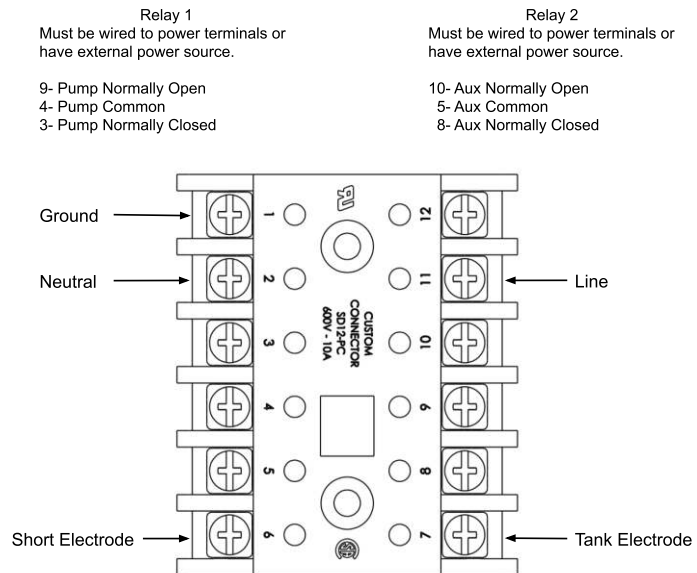

4.2.2.1 High Level Alarm

This configuration will trigger the relay when the liquid reaches a high level.

For this configuration connect the alarm through the normally open relay on the base (Relay 1: terminals 4 and 9 or Relay 2: terminals 5 and 10).

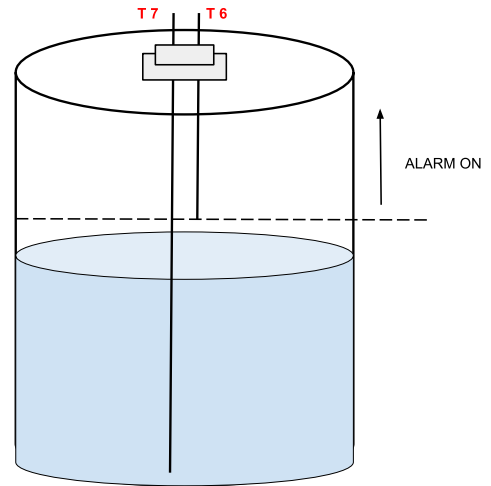

4.2.2.2 Low Level Alarm

This configuration will keep the liquid level at or above a specified level.

For this configuration connect the alarm through the normally closed relay on the base (Relay 1: terminals 4 and 3 or Relay 2: terminals 5 and 8).

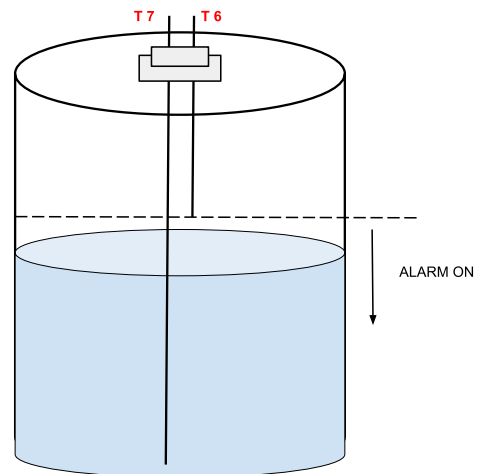

4.3 AM-LL7H Wiring

4.3.1 AM-LL7H Differential Level Wiring

Differential Level Service uses two or three level electrodes: one short, one long, and one ground that is always in contact with the liquid (electrode or tank). As the liquid falls below the long electrode, the relay is activated, and it is again tripped when the liquid rises to the short electrode. This leaves a neutral region in between the long and short electrodes where the liquid is at an acceptable level. The pump will not turn on or off as long as the level remains within this acceptable range. Use of this configuration allows a certain level tolerance that can be adjusted by changing the distance between the two electrodes.

NOTE: If the tank is metallic and grounded, connect electrode to the tank. For nonconductive tanks, use an electrode that is constantly submerged.

4.3.1.1 Pump Up

When the liquid level falls below the longest electrode, the normally closed relay will engage, and the pump will turn on. When the liquid level reaches the shortest electrode, the relay will disengage, and the pump will turn off. For this configuration connect the pump through the normally closed relay on the base (terminals 4 and 6).

NOTE: Pump must be powered externally.

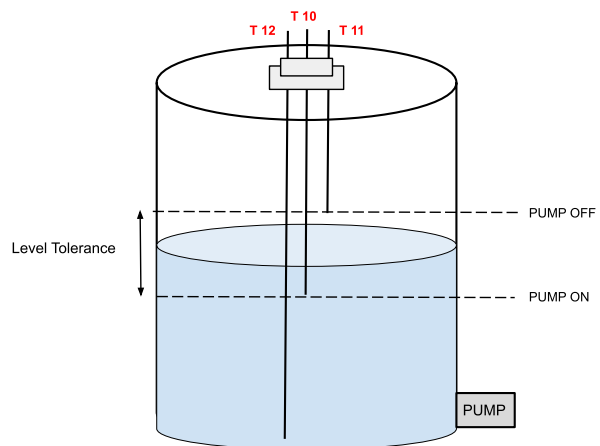
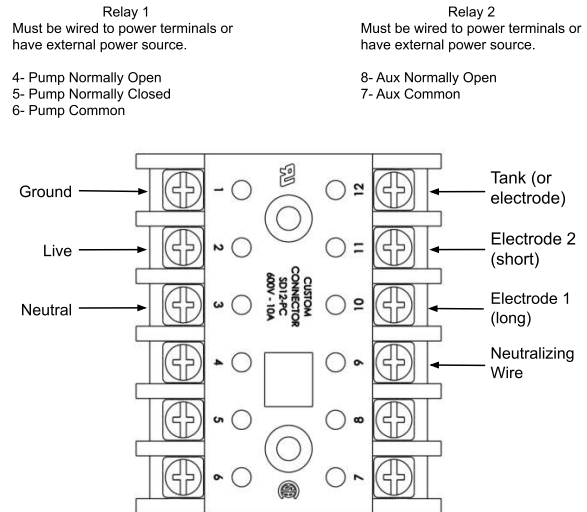

4.3.1.2 Pump Down

When the liquid level reaches the shortest electrode, the normally open relay will disengage, and the pump will turn off. When liquid levels fall below the longest, the relays will engage, and the pump will turn on. For this configuration connect the pump through the normally closed relay on the base (terminals 5 and 6).

NOTE: Pump must be powered externally.

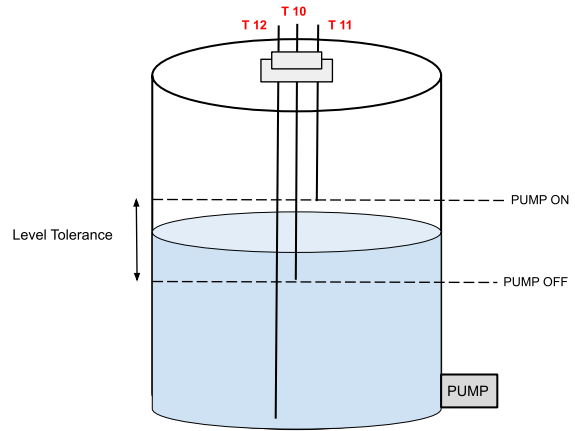

4.3.2 AM-LL7H Single Level Wiring

For Single Level Wiring, disconnect the longest electrode (terminal 10).

Single Level Service uses one level electrode and one ground (electrode or tank). The pump can either be normally off or normally on, depending on application. As soon as the liquid reaches the level electrode, this will create a circuit with the ground electrode or the tank and activate the relay switch. This configuration may be used with a slowly changing liquid level to maintain a very exact height.

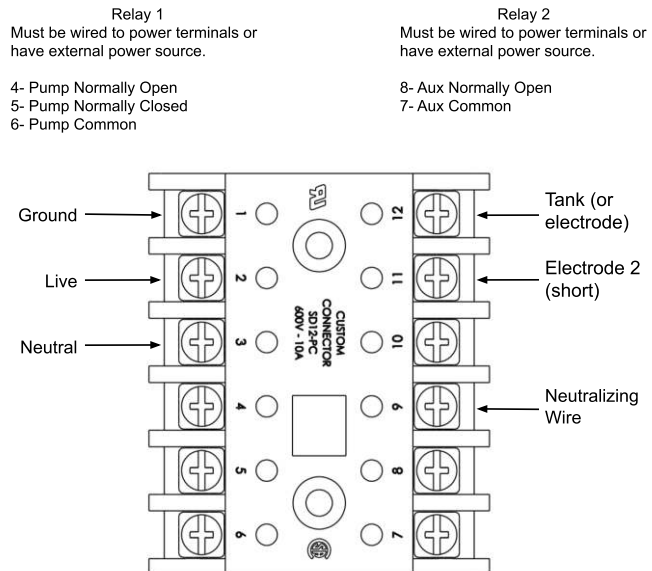

4.3.2.1 High Level Alarm

This configuration will trigger the relay when the liquid reaches a high level.

For this configuration connect the alarm through the normally open relay on the base (terminals 4 and 6).

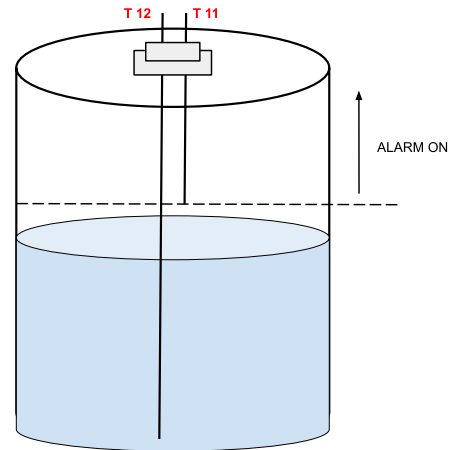

4.3.2.2 Low Level Alarm

This configuration will keep the liquid level at or above a specified level.

For this configuration connect the alarm through the normally closed relay on the base (terminals 5 and 6).

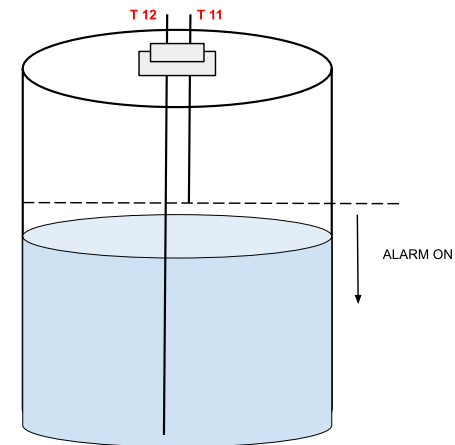

5 Accessories

5.1 Suspended Electrodes (AM-ELE)

The AM-ELE is a weighted electrode that is suspended by a flexible PVC cable. AM-ELE suspended electrodes are recommended for conditions where installation space is limited, where electrodes need to be easily adjustable, or where electrodes need to be easily removable for frequent cleaning.

Depending on liquid level operating type and tank conductivity, between 1 and 3 electrodes are required. The electrodes can be connected directly to a base or through a junction box.

- Wetted material: 316 Stainless steel electrode, PVC (temperature rating 130°F/54°C)
- Electrode cable length: 15 feet
- Cable can be shortened if needed. Do not submerge cable with a visual defect on a jacket.
- To extend cable length, use a junction box (AM-JB2) and additional cable (AM-CBL)

5.2 Junction box

If the distance between the electrodes and the LL controller exceeds 15 ft, a junction box can be used to extend the electrodes the remaining distance. The junction box allows the user to create a water-resistant connection to the electrodes using an additional cable. The junction box can be mounted on top of a tank, or wall-mounted next to it.

- AM-JB2 meets NEMA 4X & IP66 specifications.
- There are 2 blocks of 6 terminals, so it can be used for more than one tank.
- Terminal specifications: Nominal Voltage: 450 V, Nominal Current 24 A, Wire gauge 26-12 AWG

5.3 Spare parts:

- Base (A26-22)
- Fuse (Ratings: 1A 250 VAC, slow blow. Dimensions: Glass, 5x20mm)
- Liquid tight plug (1/4" hole)

6 Warranty

Both the LL3 and LL7H controllers come with a 2-year warranty from the date of purchase.

7 Troubleshooting

1. Both controllers are a simple analog design. The most frequent source of issues is incorrect wiring. There is a replaceable fuse if needed, in the case of miswiring.
2. Ensure 120/240 VAC jumpers are set properly. Refer to labels on the PCB for correct jumper orientation.
3. Check if electrodes are cleaned. Residue may prevent a contact from being formed.
 - a. Advanced: check continuity between electrode tip and cable end. Alternatively, touch the tank and short electrode together. If the relay triggers, everything works as it should. If the relay doesn't trigger, try shorting the appropriate terminals on the base. If this works, replace the electrodes being used. If this doesn't work, check fuse, input power, and lastly, contact support.

7.1 AM-LL7H

1. Adjust sensitivity using the trim pot if needed. If the maximum sensitivity is surpassed, the device will stop operating (this usually occurs around 60-100% CW).
2. The relay can be triggered manually to verify proper connection or do a manual test.

7.2 AM-LL3:

1. Check if the LED turns ON when two electrodes are connected.
2. Wait up to 6 sec (see delay feature above)

Should problems persist, contact an AquaMetrix specialist at support@wateranalytics.net.